



**TITAN
makes it
better.**

More efficient. More flexible. More individual.
Or in short: simply better.



**Better viewed
in the round.**



SIEGENIA stands for 360° room comfort. In order to do justice to this commitment, we always look at each product from every angle. From the perspective of the fabricator, from the point of view of the user and with an eye on sustainability. However you look at it, TITAN is the best hardware because it is continually being improved. You will notice this in production and your customers will notice this in the operation.

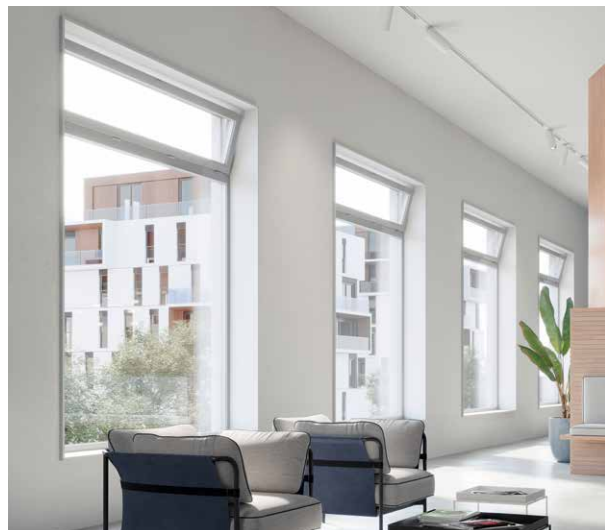

TITAN makes it more individual.

No matter what the future project and customer requirements might be – TITAN covers all wishes in one system. An economical initial configuration or a design solution with concealed pivots? Large glass surfaces, heavy sashes, barrier-free thresholds or the use of smart motors for the highest comfort demands? All these enquiries have one answer: TITAN.

Clever accessory options allow you the freedom of design to react quickly and flexibly to individual customer wishes. For example, windows can be achieved with the TITAN opening restrictor that comply with the demand for universal design: especially easily and safely operated and designed for all generations. The accessories can easily be integrated into your production and combined with each other.

TITAN makes it

more efficient.

Time savings at every stage of production and smooth operation.
TITAN lets you combine the two.

**Masterfully coupled: faster and more precise,
for automatic and manual assembly.**

The special TITAN click-on coupling points make for extremely efficient coupling that is not affected by tolerances – for any assembly technique. If necessary, linkages and extensions on the bottom side and hinge side can be installed on the pre-weld profile. When installing on the finished sash, simply slide underneath the corner drive to enable quick positioning. The fine tothinging ❶ with a 1.5 mm tooth pitch and large coupled bevels guarantees a reliable and precise joint with minimal play in the coupling – precision that can be felt in the smooth operation of the window. What's more, all sash components feature efficient groove clamping ❷ for quick and secure assembly.

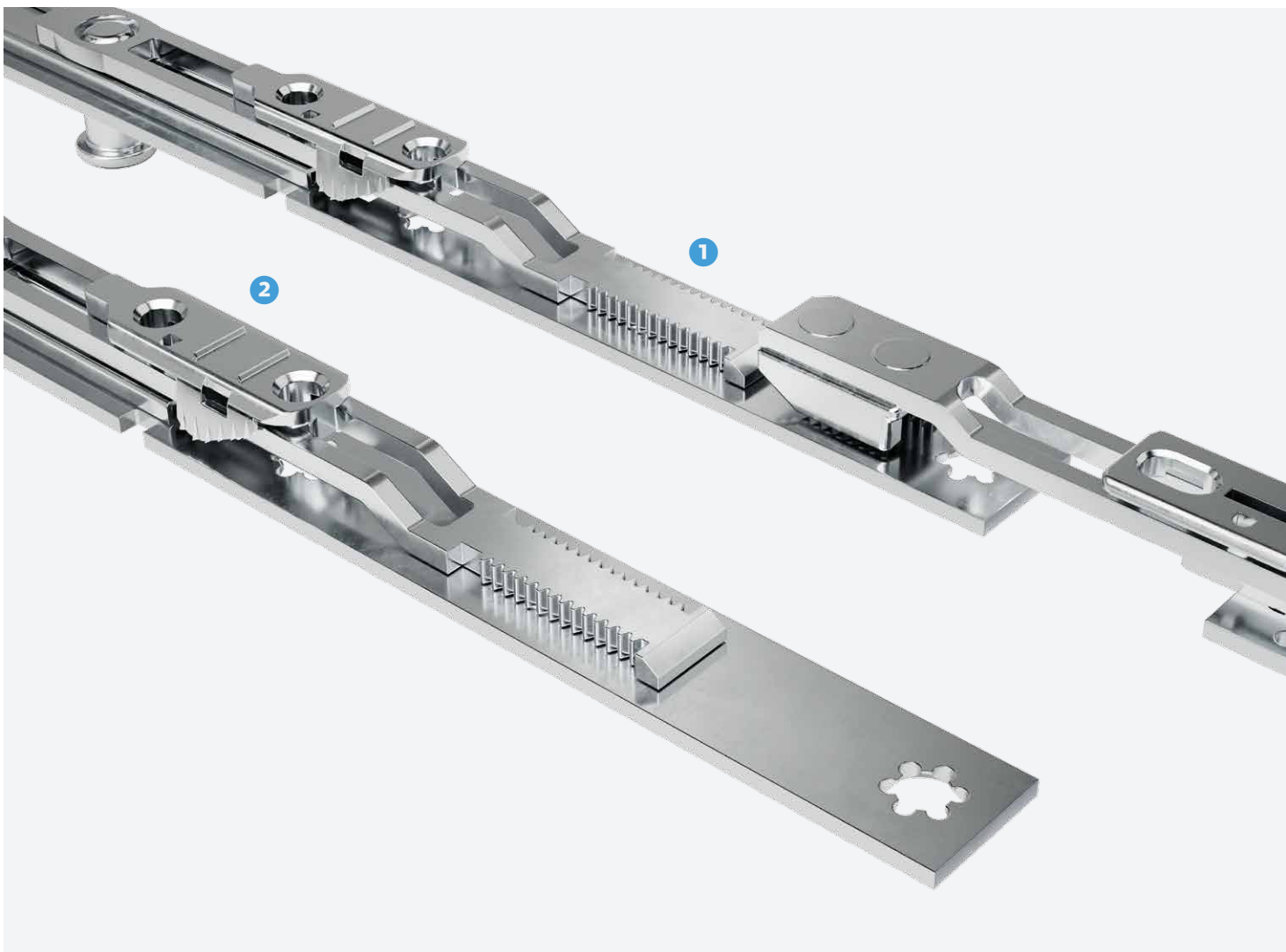

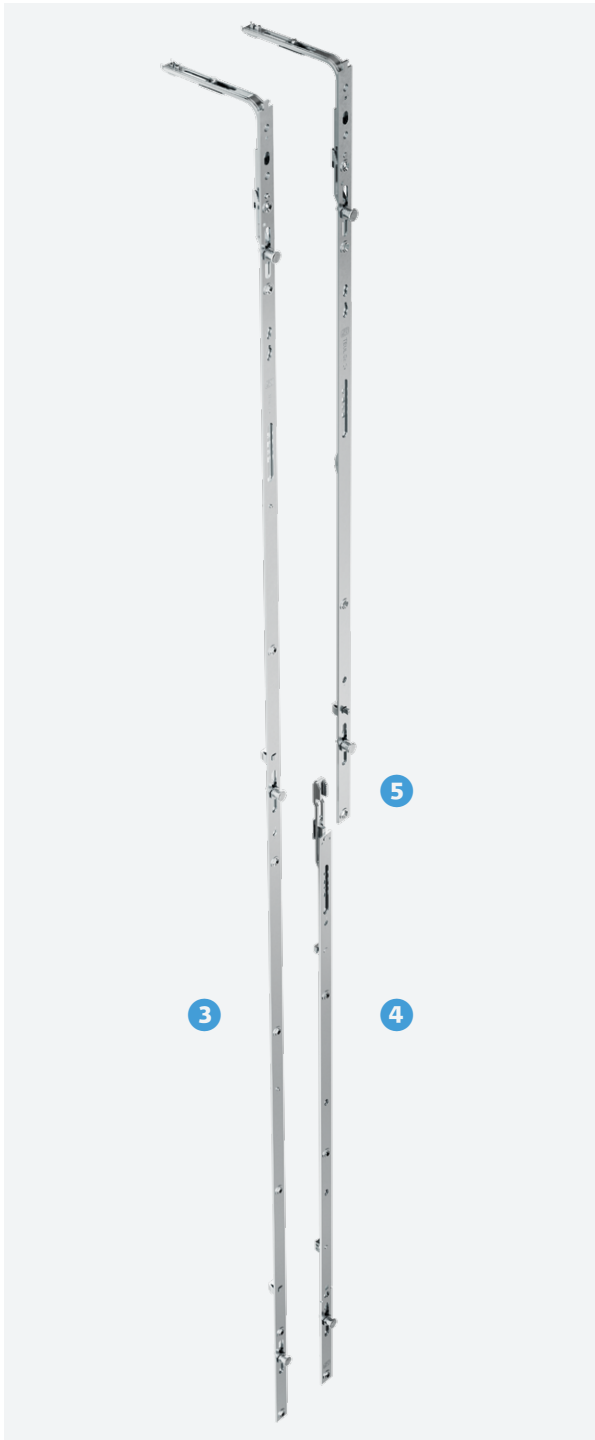

More flexibility in fabrication: short or long components from a single kit.

Only TITAN gives you the freedom to choose. Corner drives on the hinge side come in five sizes. This means that window rebate heights of up to 2,200 mm can be achieved with just a single long component 3. This has the benefit of ensuring an accurate fit of the cams and quick assembly. Depending on the production layout and to enable particularly ergonomic handling, short components with linkages 4 can alternatively be used. These can be placed on the pre-weld profile beforehand or quickly inserted afterwards using a click-on coupling point 5.

Outage times? Shorter by far.

Precisely cropped lengths and faster handling: allowing longer operating times to be achieved with the punch when cropping.

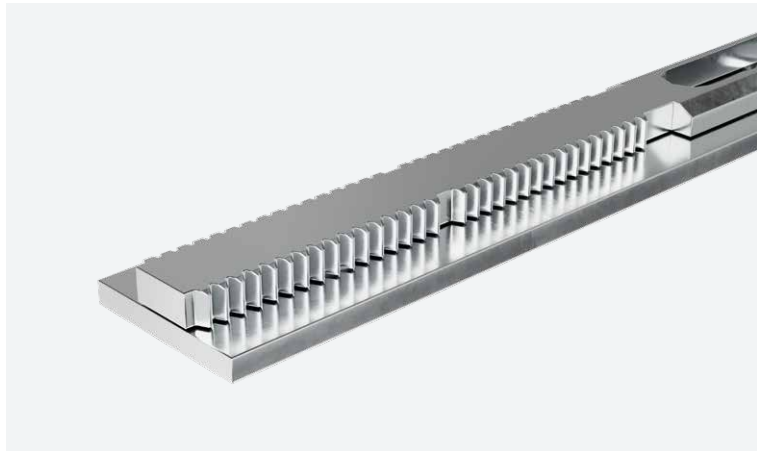

Production tolerances? Nowhere to be felt. Nowhere to be seen.

Our TITAN comfort mushroom cam 6 is the most powerful locking pin on the market, a fact that is evident right from the production stage. It also ensures continuous and fully automated compensation of high tolerances. The stop plate 7 guarantees a flawless, high-quality appearance. Any imperfectly punched cover rails or gaps between the components are smoothed out and concealed. The intersection between the gear and the stay is also protected against corrosion.

TITAN makes it

more flexible.

The innovative tilt points: a high level of pre-assembly, fewer components, a greater variety of solutions.

Tilt points: efficient and powerful.

All TITAN tilt points are truly multi-talented. Their ingenious design combines long-lasting ease of use, effective intruder resistance and highly efficient fabrication. The high level of pre-assembly in the TITAN system saves a significant amount of time, as well as considerable storage space. The click-on coupling point allows you to produce couplings quickly and securely and offers you the greatest possible flexibility for all your customer requirements in three variants.



Tilt point with integrated sash lift 1. Even the basic version sets a high standard. The slider is always perfectly supported on the bottom rod of the frame, thus automatically offsetting the production tolerances. The self-adjusting comfort mushroom cam serves as a locking pin that enables consistently optimised adjustment of the window.

Tilt point with sash lift 1 and sash lift roller 2 in the frame part. Lifting the sash gently and early reduces the abrasion marks on the frame part to an absolute minimum. The low number of screw points – as with all TITAN tilt points – ensures fast production processes. Extra operating safety is guaranteed by the optional mishandling device 3, which is also offered preassembled – for even more efficient production processes.

Comfort mushroom cam.

The high-performance locking pin combines a high level of intruder resistance with superior ease of use. Thanks to its automated height adjustment, it is able to automatically compensate for airgap tolerances and guarantees a smooth-running and secure window that is always optimally adjusted.

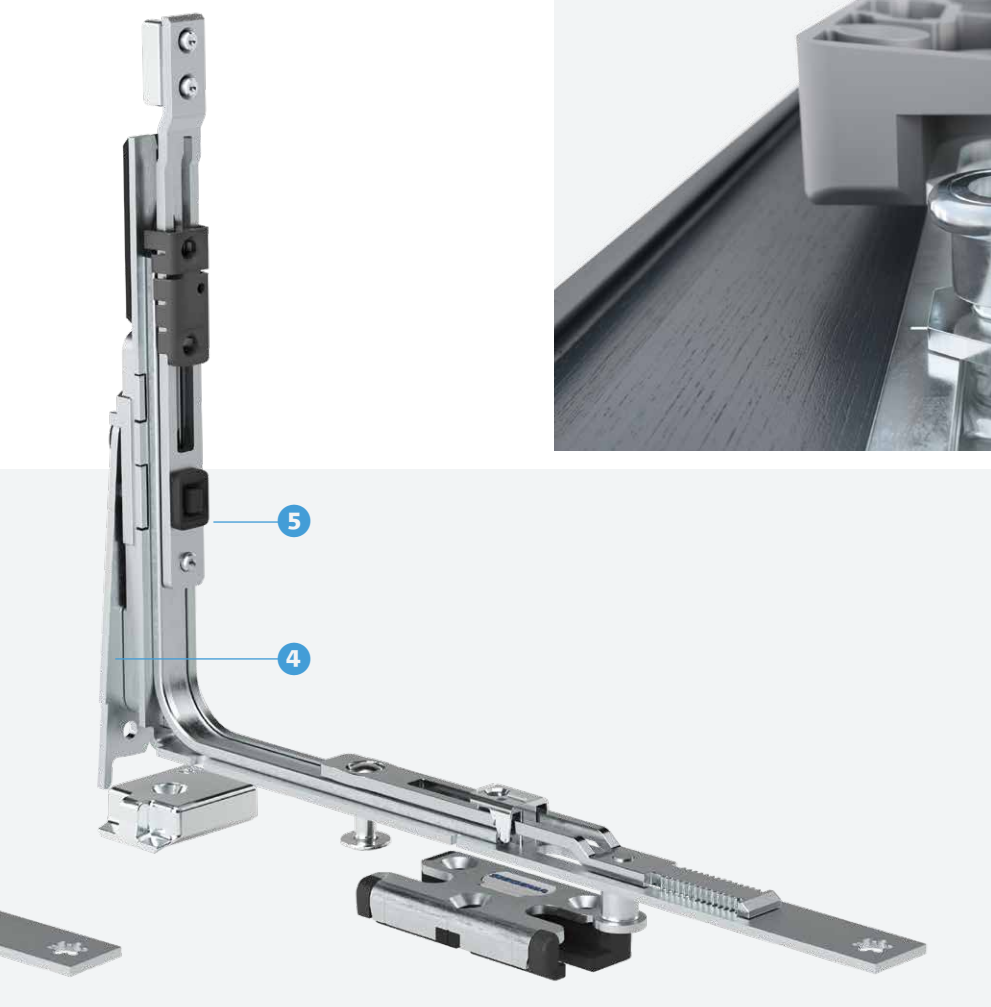

Tilt point with sash lift arm 4. The most effective sash lifter in the industry is especially well suited to large, modern windows. Heavy sashes are lifted early and discreetly and then closed gently. The visual effect on secondary sash elements is striking: the two sashes are always exactly aligned with each other. The integrated mishandling device 5 facilitates convenient and reliable operation.



Frame parts with logo clip.

All TITAN frame parts are specially adapted to the comfort mushroom cam, and the combination of steel and PVC minimises the operating forces that occur when closing the window and ensures optimum sealing. The customisable logo clip creates a uniform appearance and can easily be ordered separately or pre-assembled on request.

SIEGENIA®
brings spaces to life

Head Office:
Industriestraße 1–3
57234 Wilnsdorf
GERMANY

Phone: +49 271 3931-0
Telefax: +49 271 3931-1333
info@siegenia.com
www.siegenia.com



You can find address details for our
international sites at: www.siegenia.com

SIEGENIA worldwide:

Austria Phone: +43 6225 8301
Benelux Phone: +31 613 143773
China Phone: +86 316 5998198
France Phone: +33 3 89618131
Germany Phone: +49 271 39310
Great Britain Phone: +44 2476 622000
Hungary Phone: +36 76 500810

India Phone: +91 124 4121647
Italy Phone: +39 02 9353601
Poland Phone: +48 77 4477700
Russia Phone: +7 495 7211762
South Korea Phone: +82 15445369
Switzerland Phone: +41 33 3461010
Turkey Phone: +90 216 5934151
Ukraine Phone: +38 044 4065793

Contact your distributor: